

Mareli Systems

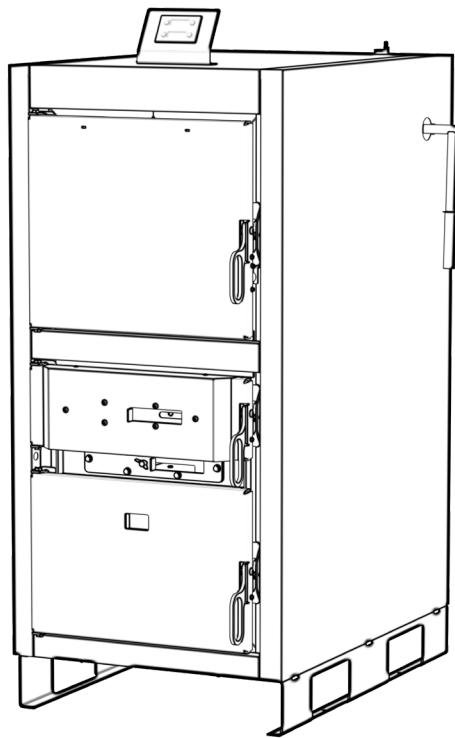

LCG 12 / 16 / 22 / 32 / 40 / 50 KW

WOOD GASIFICATION BOILER

Assembly and exploitation manual

Mareli Systems

Observing the prescriptions of the present manual is in the user's favour and is one of the warranty conditions. Compliance with this instruction is in the interest of the consumer and one of the warranty terms.

These instructions are an integral part of this product. All rights reserved. Reproduction of content of this document and transfer to third parties is not allowed without written approval from manufacturer. Make sure the instructions are always with the device, even if its sale / transfer of another owner to the user or staff authorized for maintenance or repairs to consult.

INSTRUCTIONS FOR SECURITY:

- This appliance is not intended for use by people (including children) with limited physical, sensory or mental abilities or lack of experience and knowledge. The installation must be performed by a qualified expert in the field of heating installations or authorized by "Mareli Systems' service. The place and way of connecting the boiler should be selected carefully in accord with the safety instructions. Install away from flammable objects!
- Before starting any operation, the user must read and fully understand the contents of this instruction manual. Incorrect setup may cause hazardous conditions and / or incorrect function of the boiler;
- Do not wash the boiler with water. Water can get inside the fireplace and damage the electronics and cause an electric shock;
- Do not put clothes to dry on the boiler. Any clothes hangers and other objects must be located within a reasonable distance from the fireplace. Fire hazard;
- The user is fully responsible for the proper use of the product which exempts the company from liability of any users errors or misbehaviour or omissions;
- Any intervention or replacement that is made by unauthorized people or using non original spare parts for the product can be risky for the user and release the company from all liability;
- Most surfaces of the boiler are extremely hot (the bottom door, glass, flue pipe, etc.). Avoid contact with these parts before assuring yourself that you use temperature resistant gloves as well as suitable temperature resistant instruments;
- Under no circumstances should the fire be ignited with the doors open or broken glass. For igniting the boiler, only the middle door must be opened.
- The product must be electrically connected to a system equipped with an effective earth conductor. (Must be grounded);
- Turn off the boiler in case of failure or malfunction;
- When installing the product all fire safety requirements must be respected.
- Periodically check and clean the smoke outlet ducts of the boiler (connection to the flue pipe);

TECHNICAL DATA

LCG	12	16	22	32	40	50
Nominal heat output (kW)	12	16	22	32	40	50
Heat output range (kW)	12	16	11-22	16-32	20-40	25-50
Boiler class EN 303-5:2021	5					
Required chimney underpressure (Pa)	14	14	14	18	18	21
Water amount in boiler	104	104	120	130	140	150
Exhaust gas temperature at nominal heat output	120	140	165	160	150	150
Exhaust gas temperature at minimal heat output	-	-	100	100	100	95
Minimum operating time at rated power (nominal Q) (h)	3					
Min. inlet water tem. at the boiler supply water connection (°C)	60					
Max. temp. (°C)	90					
Fuel type	A, wood logs, by norm 14964-5					
Fuel moisture content (%)	max 25 %					
Fuel length (mm)	500	500	500	500	500	500
Fuel loading chamber capacity (L)	69	69	103	103	103	136
Combustion chamber type	UNDERPRESSURE					
Required minimum accumulation volume(tank) next to boiler	by EN 303-5:2021					
Supply voltage (V~)	230					
Frequency (Hz)	50					
Weight (kg)	376	376	424	449	479	526
Max. operating pressure (bar)	3					
Flue gas tube - external diameter (mm)	149					
Heating appliance working	with fan					
Heating appliance working	under non-condensing conditions					
Energy efficiency class of boiler	A+					

	READ THESE INSTRUCTIONS CAREFULLY BEFORE INSTALLING THE BOILER TO HEATING SYSTEM!
	BOILER MUST NOT OPERATE IN FLAMMABLE AND EXPLOSIVE ENVIRONMENT.
	BEFORE ANY WORK ON THE BOILER, ELECTRIC ENERGY MUST BE SWITCHED OFF.

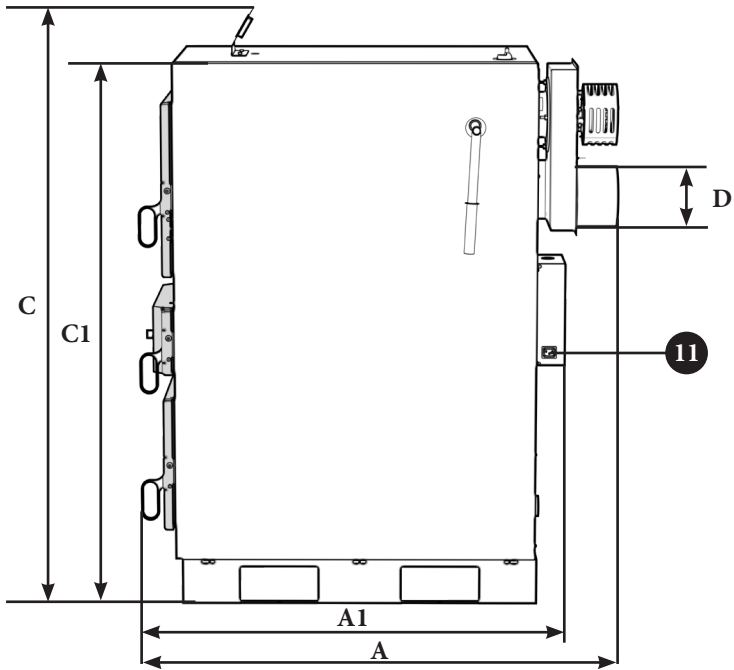
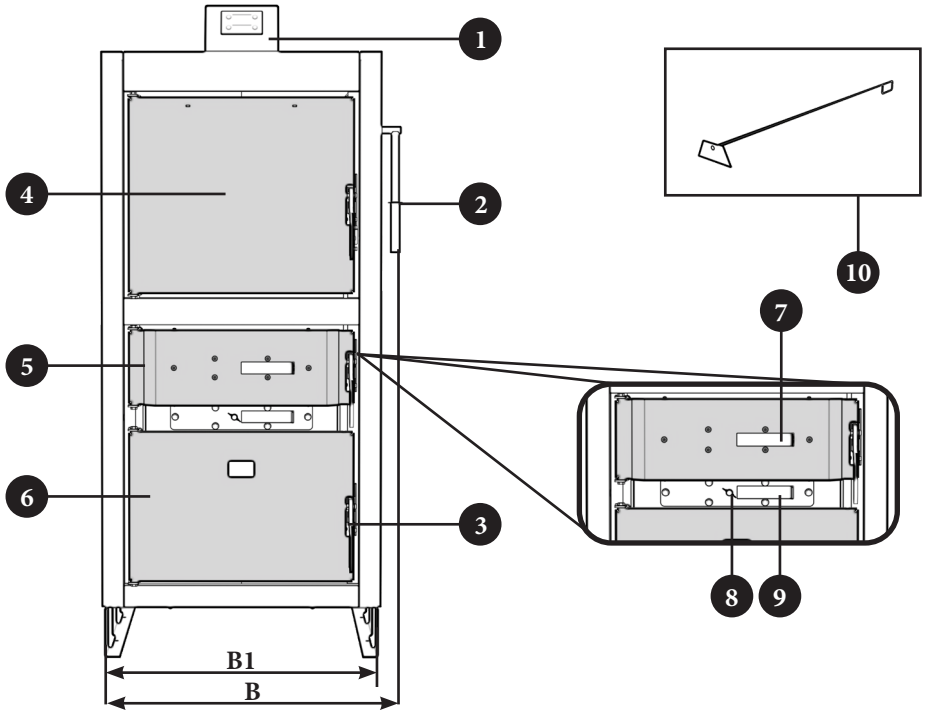

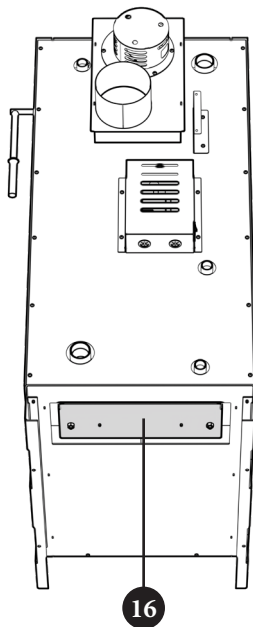
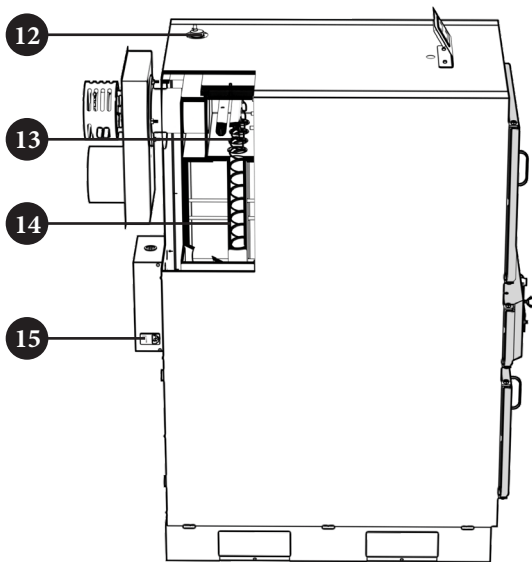
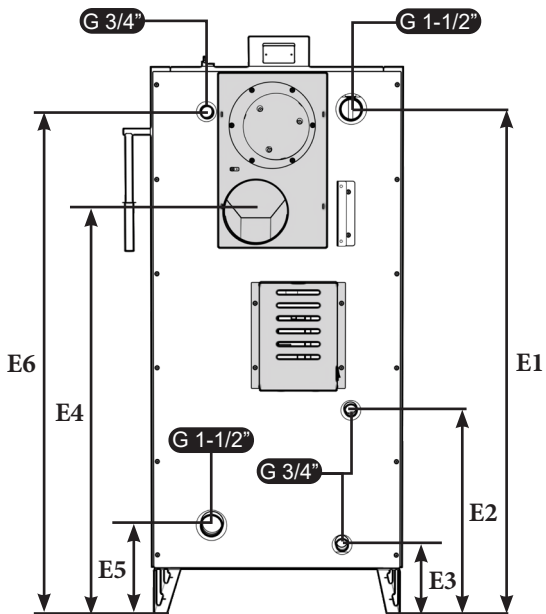
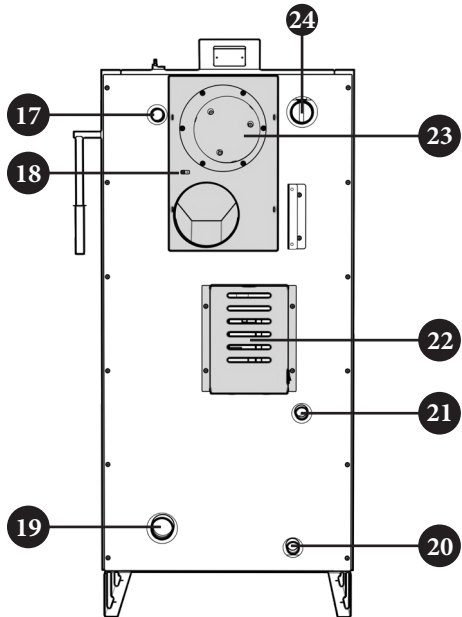

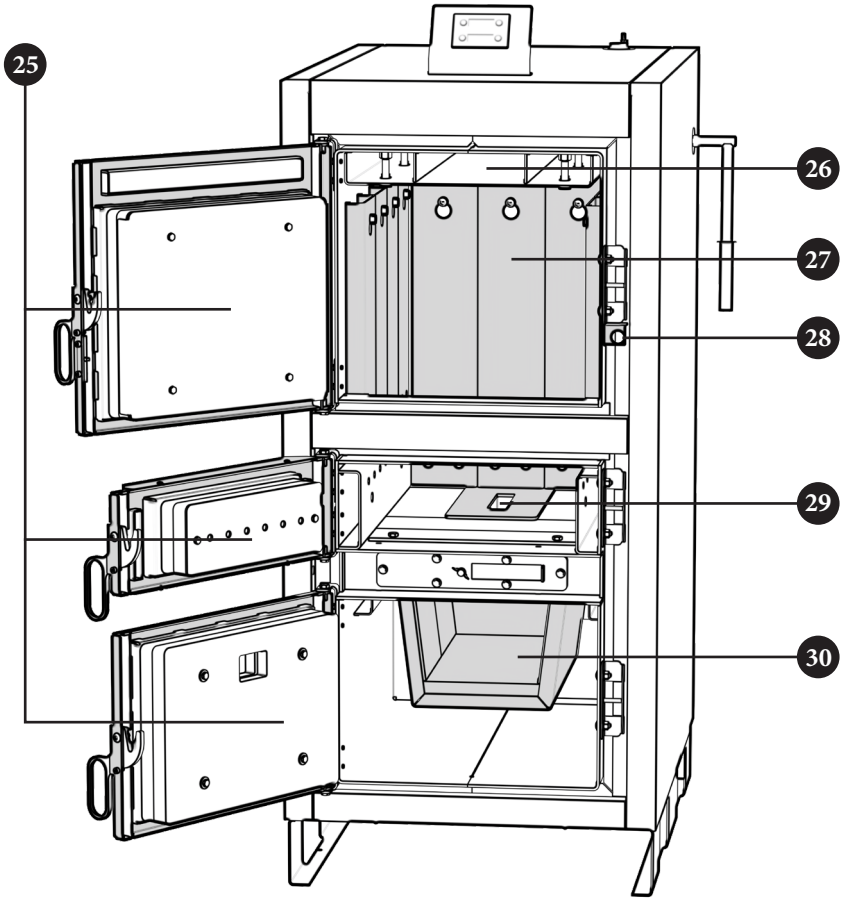

LCG	A (mm)	A1 (mm)	B (mm)	B1 (mm)	C (mm)	C1 (mm)	D (mm)	E1 (mm)	E2 (mm)	E3 (mm)	E4 (mm)	E5 (mm)	E6 (mm)
12	1140	1021	563	490	1387	1280	Ø149	1180	430	165	943	210	1174
16	1140	1021	563	490	1387	1280	Ø149	1180	430	165	943	210	1174
22	1135	1016	663	590	1387	1280	Ø149	1180	480	165	943	210	1174
32	1185	1066	663	590	1387	1280	Ø149	1180	480	165	943	210	1174
40	1255	1136	663	590	1387	1280	Ø149	1180	480	165	943	210	1174
50	1255	1136	663	590	1537	1430	Ø149	1330	630	165	1093	210	1324

1	Digital boiler display	16	Bottom service door
2	Flue gas tube cleaning lever	17	STS thermal safety valve connection 1 capillary bulb
3	Door handle	18	Exhaust temperature sensor
4	Upper boiler door	19	Water inlet
5	Middle boiler door	20	Drainage valve
6	Lower boiler door	21	STS thermal safety valve connection 2 mains inlet
7	Primary air regulator	22	LCG electronic control board
8	Fixing screw for secondary air regulator	23	Exhaust fan
9	Secondary air regulator	24	Water outlet
10	Cleaning tool	25	Heat resistant plate
11	Connection for pump	26	Duct for smoke absorption
12	Deaerator	27	Protection cladding
13	Cleaning mechanism for flue gas tube	28	Open door sensor
14	Turbulator	29	Burner
15	On / Off power switch	30	Burning chamber

Mareli Systems

1. GENERAL INFORMATION

Steel boilers LCG, with an rated thermal output 22, 32, 40 and 50 kW are constructed for wood firing and aimed for heating of small and middle sized premises. Due to the applied wood gasification principle, wood is totally burned. Widely sized combustion chamber enables the firing with wood pieces of 500 mm.

One filling period lasts min. 3 hours, with the possibility of prolonging it to the whole day, if the heating requirement is decreased. The functioning of the boiler is steered by the built-in regulation system. The boiler must be connected to the central heating system through an appropriately sized water tank.

The LCG boiler is produced in compliance with the EN 303-5 norm, which enables the required level of functioning and minimal environmental pollution, through the firing with wood. The boiler is aimed for firing with wood. The system of flue gases conduction and their additional burning out, enables its high efficiency, which makes this product extremely economical. Widely sized combustion chamber door enables firing with large pieces of wood and a very simple and easy cleaning and maintenance. One filling period lasts minimum 3 hours, depending on the nominal thermal output. There is also a possibility of prolonging the firing process to the entire day, if the heating requirement is decreased.

An integrated controller regulation system controls the functioning of the boiler as well as the circulation pump and the primary heating circuit. The LCG boiler is very simple to handle, while the built-in regulation enables its reliable functioning. Through the compulsory connection of the water tank to the heating system, the optimal functioning of the boiler is achieved and the produced heat is saved, which enables consumption exactly according to the need. The firing process can be implemented in suitable period of the day. If the outdoor temperature is not very low, the room heating and the sanitary hot water production can be extended to the period of few days. The boiler is delivered together with thermal insulation, covered by a metal casing and it is pre-wired.



Fuel: wood having moisture content to 20% (max. 25%).



This demand for moisture content is fulfilled with wood dried on air at least 12 months.

2. POSITIONING AND ASSEMBLY

The installation of the boiler has to be carried out by the authorized person. We suggest the boiler to be installed on the solid concrete basis, which height is between 50-100 mm. The boiler room has to be absolutely protected from freezing and properly ventilated. The boiler has to be set up in order to enable its connection to the chimney as well as its servicing during the functioning process, cleaning and maintenance. The connection boiler to the central heating system is obligatory through one or more water tanks, in accordance to the boiler power. It is recommended to connect a minimum of 12 liters water to each 1 L of fuel loading chamber capacity (i.e. for the 40 kW boiler the recommended water tank should be 1250 liters). The boiler should not be used without being connected to the water accumulation tank. It must be connected to the water tank exclusively through an 3-way thermic valve **maintains minimum temperature of return water into the boiler above 60°C**.

MINIMUM DISTANCE FROM THE ROOM WALLS

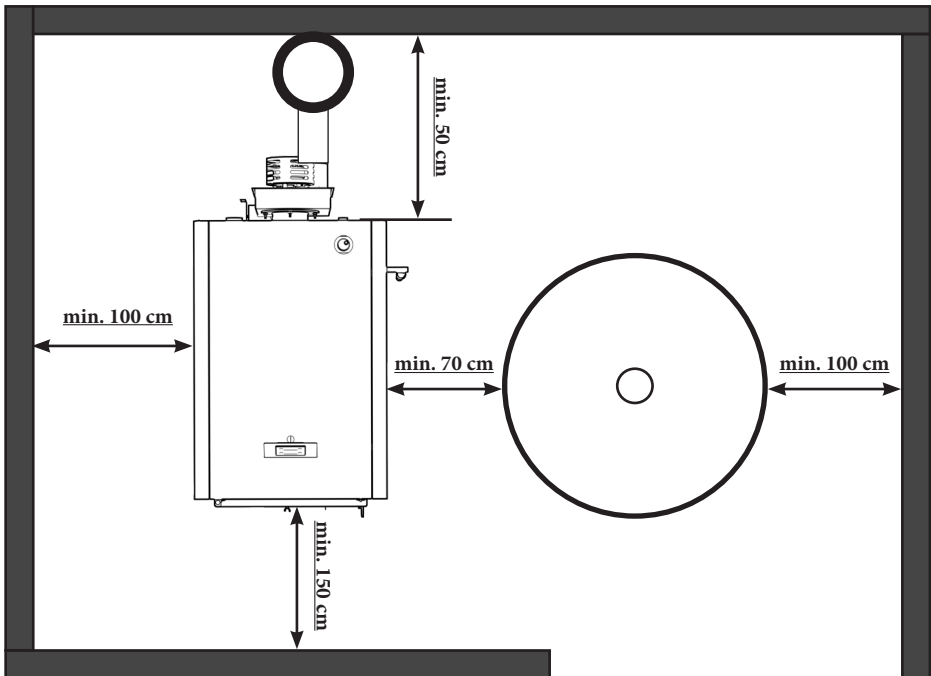

FLAMMABLE ITEMS MUST NOT BE PLACED ON THE BOILER AND WITHIN THE MINIMUM DISTANCES SHOWN

2.1 INSTALLATION OF THE COMBUSTION FAN

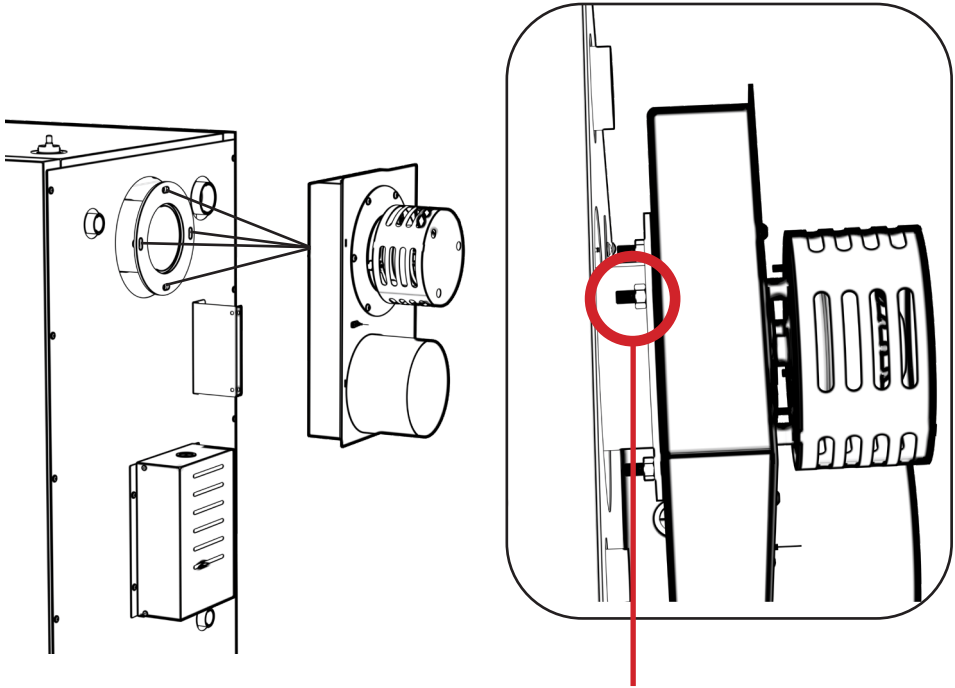

Mount the combustion fan with the threaded screws to the designated connection points. Use the 4 (M8) nuts in the mounting kit with the boiler to fix the combustion fan in place.

3. CONNECTION TO THE CHIMNEY

Properly calibrated and built chimney is the precondition for a safe operation of the boiler and economic heating. The chimney has to be well insulated, gas-proof and smooth. On the lower part of the chimney, a cleaning door has to be built in. Brick layed chimney has to have 3 layers with an stone wool thermal insulation in the middle. The thickness of the insulation should be 30 mm, if the chimney is situated inside the building, i.e. 50 mm if the chimney is situated outside the building. Inside chimney diameter dimensions depend on its height and on the boiler capacity. The temperature of the flue gases on their exit point should be minimum 30°C higher then the temperature of their condensation point. The choice and the construction of the chimney should be performed by an authorized person. Minimal distance between boiler and the chimney is 500 mm. The flue gas tube has to have an inclination of 30-45°. In order to unale entering of the condensate from the chimney into the boiler, 10 mm of the flue gas tube length has to be inserted deeper inside the chimney. It is recommended to insulate the chimney connection tube with a mineral wool of 30-50 mm thickness. All installation works must be made in accordance with valid national and European standards. At connecting a boiler to the chimney, flue gas tubes and elbows must not pass behind the fan since in that case the cleaning and maintenance will not be possible.

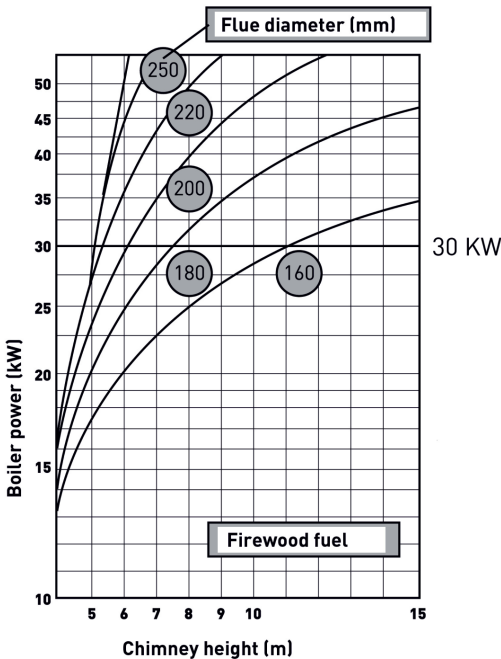
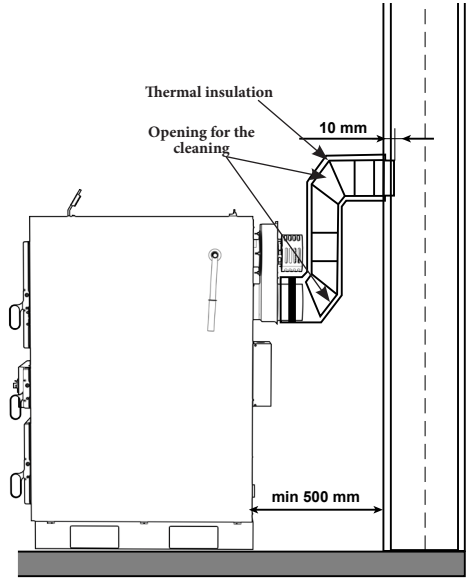
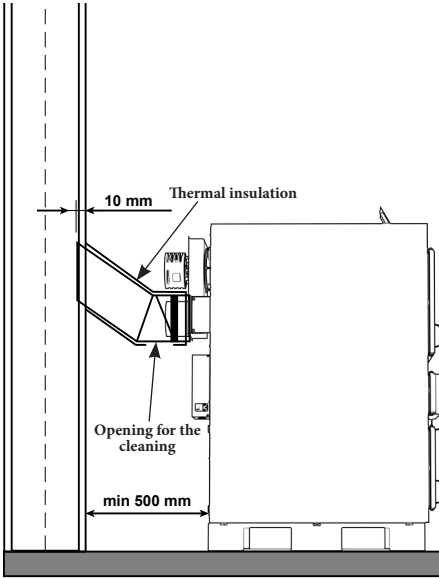

The dimensioning of the chimney is a very important condition for the operation of the boiler at optimal parameters. The chimney must be designed in such a way as to make the gases escape correctly and to keep the necessary air in the boiler. The diagrams below show how to choose the height of the chimney depending on its diameter and the power of the boiler. Choosing the right insulation for the chimney is very important and it must be 30-50 mm thick. The correct choice of the chimney diameter and height are decisive in the correct operation of the boiler. To meet the above conditions, consult the chimney manufacturer's specialists. The minimum height of the chimney for wood-burning boilers is 6 m. The chimney must be made of stainless steel elements, to reduce the influence of condensation.

FRESH AIR OPENING

Each boiler room must be equipped with an opening for supply of make up air which is dimensioned in accordance with boiler output (minimum opening area according to the below shown equation). Such opening must be protected with a net or grate. All installation works have to be performed in accordance with valid national and European standards. Boiler must not operate in flammable and explosive environment.

$$A = 6,02 \times Q$$

A - opening area in cm² Q - boiler output in kW

Example scheme for installation of an anti-condensation valve. It is recommended that the valve be at least 60 C. At the discretion of the installer, a valve with a higher return water temperature may be installed.

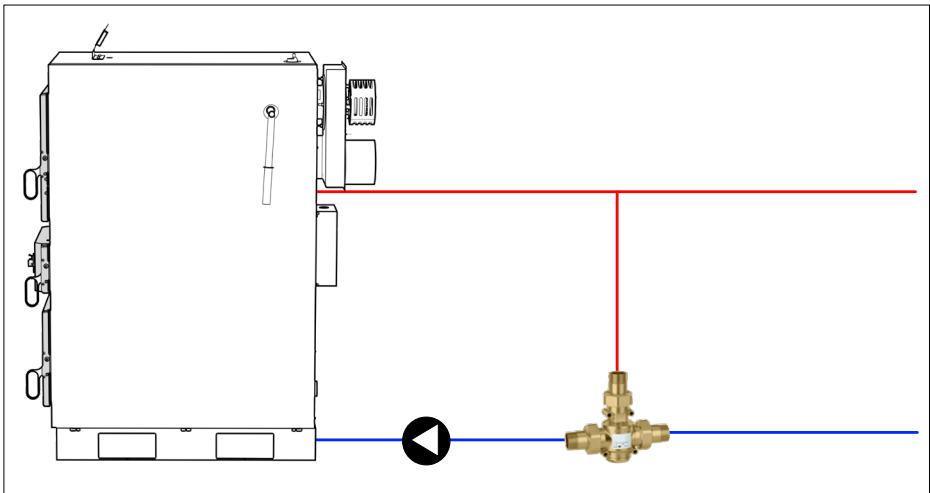

4. CONNECTION TO THE CENTRAL HEATING SYSTEM

All installation works must be made in accordance with valid national and European standards. Boiler LCG can be built to closed and open central heating systems. In both cases boiler must be fired with wooden logs. Installation has to be made, in according to technical standards, by a professional who will be responsible for proper boiler operation. The inlet pipe from the boiler to the central heating system must not pass above the top back casing cover; otherwise the removal of the turbulators and cleaning of flue gas tubes is impossible. Before connecting boiler to central heating system, the system has to be flushed to remove impurities remaining after system installation. It prevents boiler overheating, noise within the system, disturbances at a pump and mixing valve. Boiler should always be connected to central heating system by connectors, never by welding.

Example scheme 1 for boiler installation on closed central heating system with return flow protection with thermic valve (group)

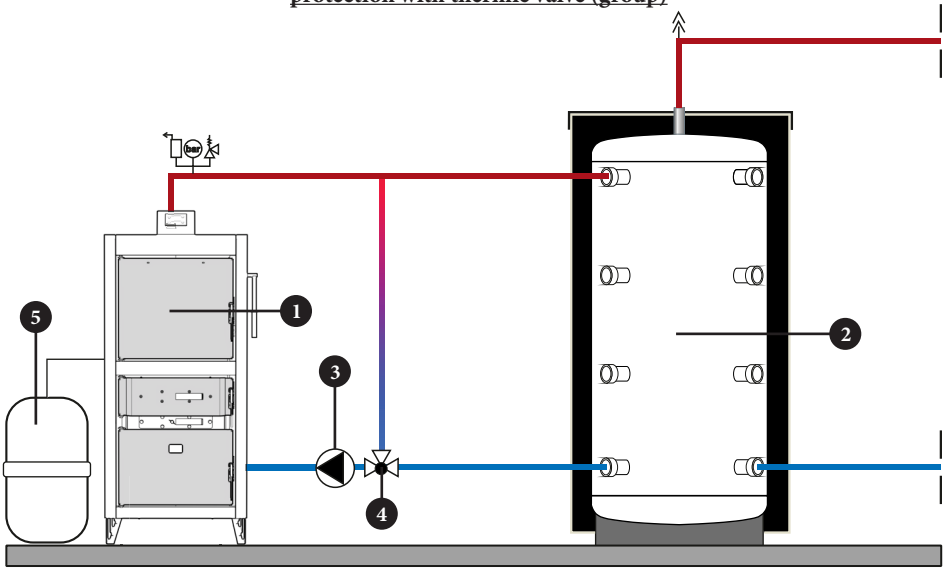

Example scheme 2 for boiler installation on open central heating system with return flow protection with thermic valve (group)

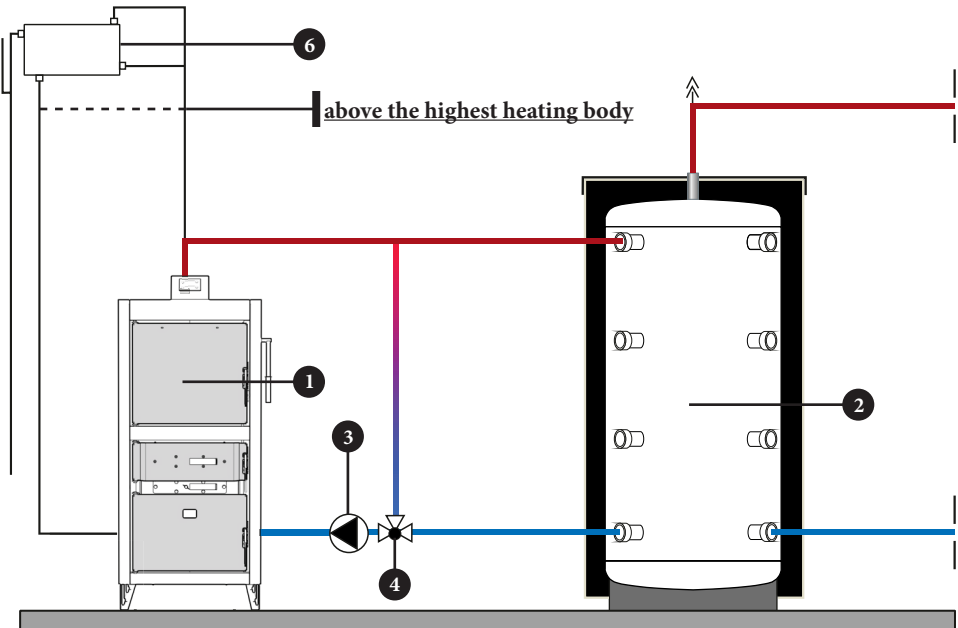

Mareli Systems

- 1 — LCG BOILER
- 2 — Water storage tank
- 3 — Boiler pump
- 4 — Return flow protection 3-way thermic valve (**min. temp 60°C**) or 3-way mixing valve with motor drive (protection valve)
- 5 — Expansion vessel for closed heating systems (approx. 10% of the total volume of installation)
- 6 — Open expansion vessel for open heating systems (approx. 7% of total volume of installation)

4.1 CONNECTION TO THE OPEN CENTRAL HEATING SYSTEM

If the boiler is aimed to be integrated into an open central heating system, one of possible way how to connect the boiler to the system is shown on Example scheme 2. In case of the LCG boilers, the boiler pump obligatory has to be connected to the boiler control unit, in order to make turning on and off of the pump depending on the temperature of the water in the boiler, to avoid boiler condensation.

Connection to an open central heating system requires the implementation of an open expansion vessel above the level of the highest heating body (radiator). If the expansion vessel is situated inside the non heated room, it has to be insulated. The volume of the open expansion vessel is about 7% of the volume of entire heating installation. The boiler has to be connected with one or more water tanks, depending on its nominal power. It is recommended to connect a minimum of 12 liters water to each 1 L of fuel loading chamber capacity (i.e. for the 40 kW boiler the recommended water tank should be 1250 liters). The boiler should not be used without being connected to the water accumulation tank. It must be connected to the water tank exclusively through an 3-way thermic valve **maintains minimum temperature of return water into the boiler above 60°C.**

4.2 CONNECTION TO THE CLOSED CENTRAL HEATING SYSTEM

In closed heating system (as in Example scheme 1) it is obligatory to build in certified safety valve with opening pressure of 2,5 bar, minimum seat diameter of 15 mm, minimum inlet connection of 1/2", minimum exit connection of 3/4" and a membrane expansion vessel. Safety valve and expansion vessel must be built in accordance with professional rules and any valve must not be located between safety valve and expansion vessel and boiler. The closed heating system must have the installed expansion vessel of larger volume (vessel volume must be approx. 10% of the heating installation volume). In all boiler types the heating pump must be connected to boiler control unit so that the heating pump switching on and off would depend on water temperature in the boiler.

The boiler has to be connected with one or more water tanks, depending on its nominal power. It is recommended to connect a minimum of 12 liters water to each 1 L of fuel loading chamber capacity (i.e. for the 40 kW boiler the recommended water tank should be 1250 liters). The boiler should not be used without being connected to the water accumulation tank. It must be connected to the water tank exclusively through an 3-way thermic valve **maintains minimum temperature of return water into the boiler above 60°C.**

BOILER THERMAL PROTECTION

According to European EN standards, boiler thermal protection must be installed in closed heating system. Boiler is factory prepared for installation of thermal protection.

IMPORTANT:

In case of any damage of boiler installed in the closed heating system due to its overheating, and boiler or system are not equipped with any thermal protection at all, or do not have properly installed thermal protection, guarantee will not be applied.

IMPORTANT:

Thermal protection must be connected to the water supply installation of the premises supplied from the water supply line and not from hydrophor. Namely, in case of failure of power supply, boiler could be overheated, and then hydrophor is not able to ensure required water supply.

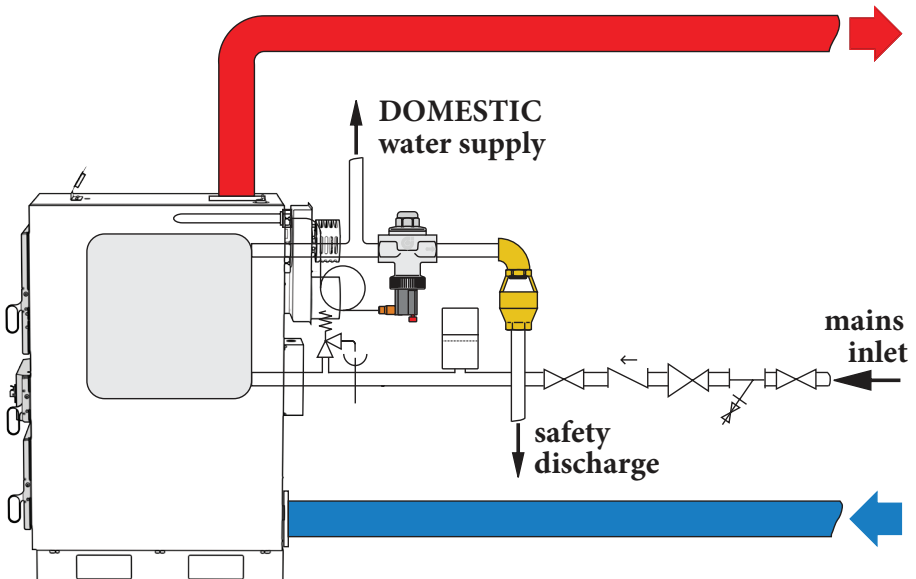
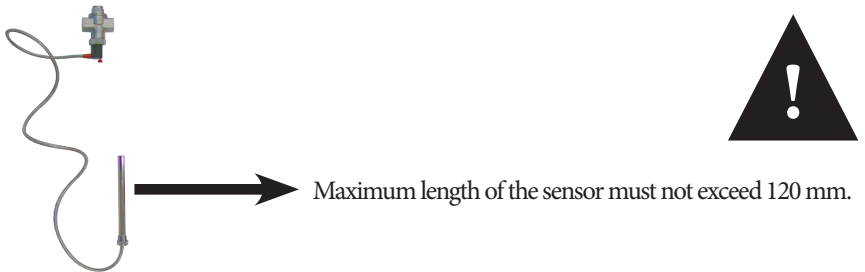

5. IGNITION PROCEDURE

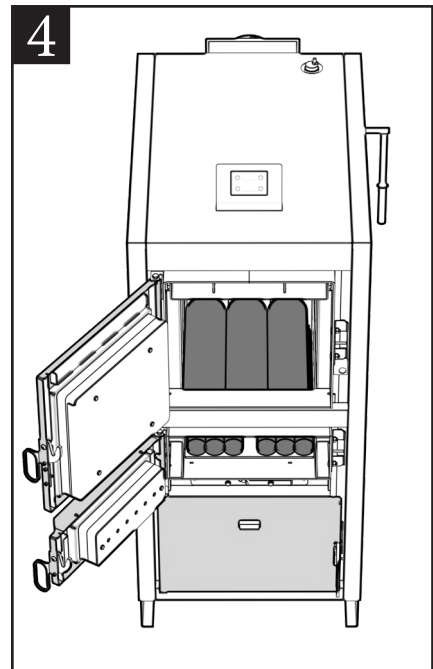
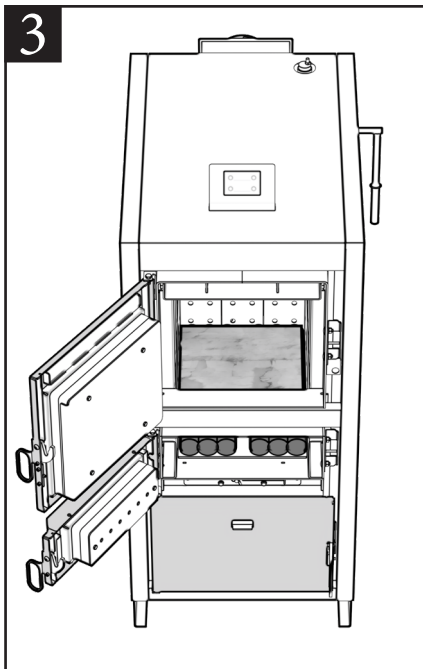
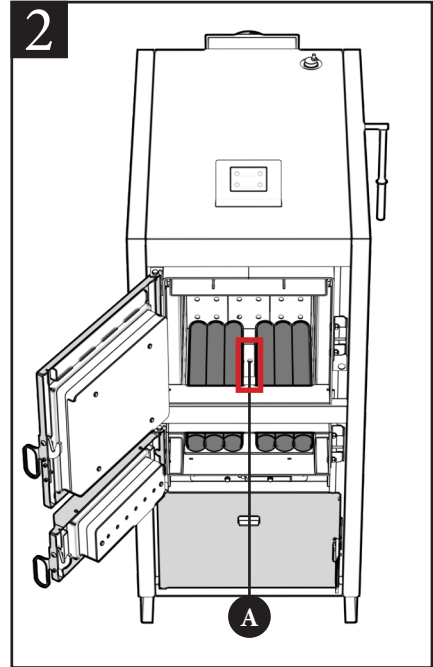
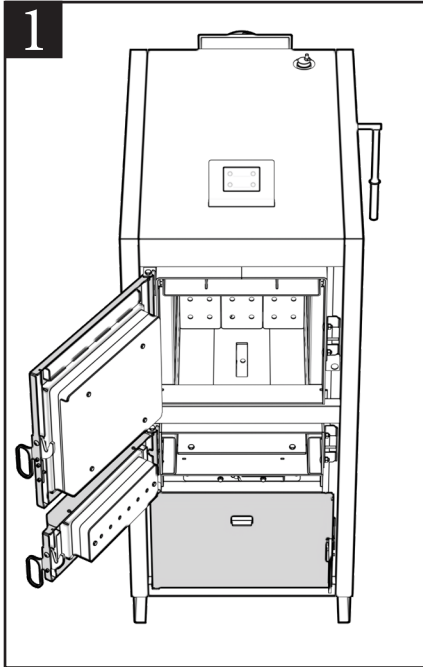

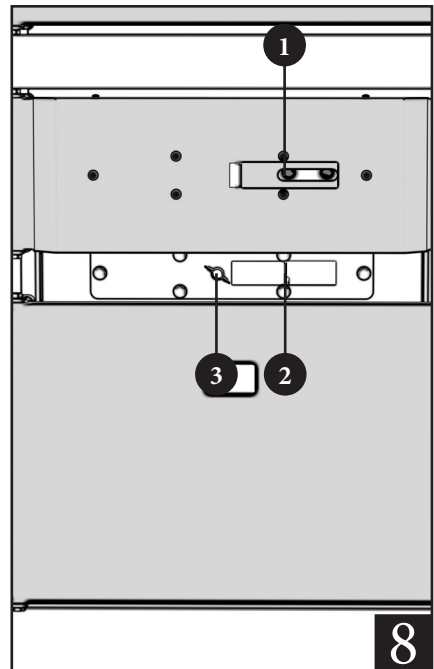
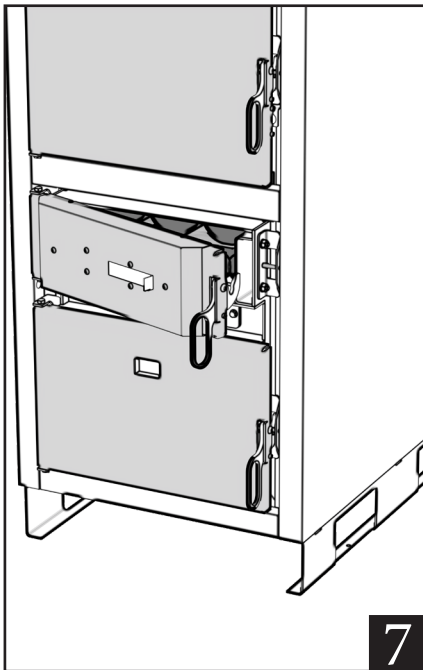
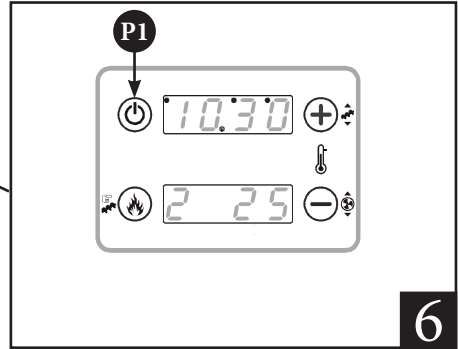
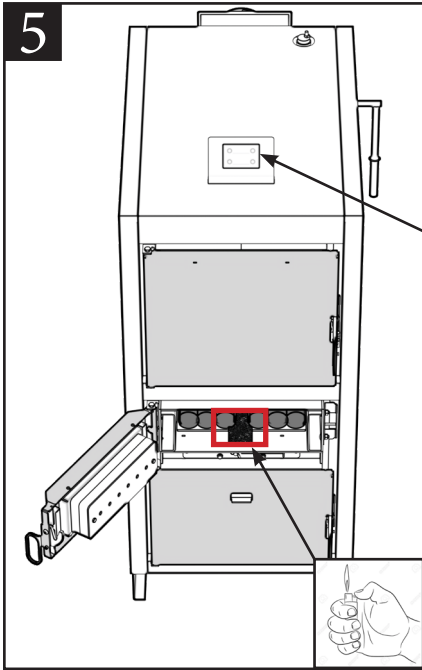

1	<ul style="list-style-type: none">• Open the top and middle doors.• Check the ash level in the combustion chamber and empty if necessary. It is recommended that you do not remove the ash in the combustion chamber during each heating-up process, but rather when the middle row of holes of the combustion chamber guards is no longer visible. This protects the combustion chamber.
2	<ul style="list-style-type: none">• Insert one layer of firewood.• Use firewood with a length of approximately 50 cm and arrange it lengthwise.• Do not completely cover the burner (A).
3	<ul style="list-style-type: none">• After the first layer of wood, lay cardboard across the whole area.
4	<ul style="list-style-type: none">• Fill the fuel loading chamber and close the fuel loading chamber door.
5	<ul style="list-style-type: none">• Keep the middle door open, insert scrunched up paper and light it.
6	<ul style="list-style-type: none">• Activate the ignition process with long press on the (P1) button;
7	<ul style="list-style-type: none">• Leave the pre-heating chamber door open for approximately 5 minutes• A bed of embers must form.• Close the middle door.
8	<ul style="list-style-type: none">• Open fully the primary air regulator (1)• Set the secondary air regulator in the half open position. (2)• Use the fixing screw to hold the position of the secondary air regulator. (3)

6. CLEANING AND MAINTENANCE OF THE BOILER

Protective gloves must be used. Ash remaining in boiler after solid fuel firing should be disposed into metal containers with a cover. As through the wood gasification principle the fuel burns out totally, the cleaning of the boiler is limited to the upper and lower combustion chamber once in a week and the cleaning of flue gas tubes on the back side of the boiler is necessary only after the heating season, i.e. min. once in one heating season. Cleaning the fan blade and fan box has to be performed when necessary.

Before each starting of the boiler it is recommended to shake the flue gas tube cleaning lever few times.



PROTECTIVE GLOVES ARE OBLIGATORY!

COMBUSTION FAN CLEANING

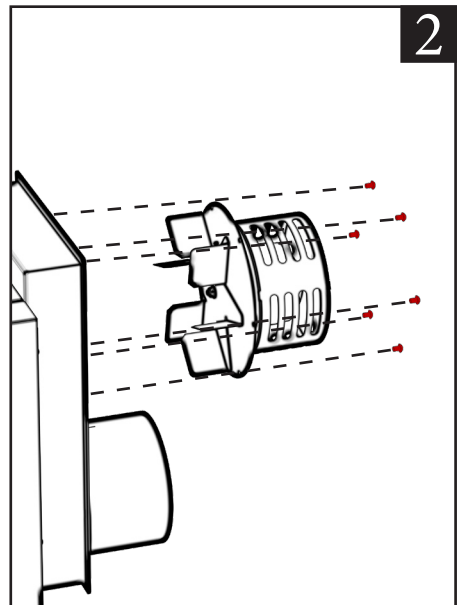
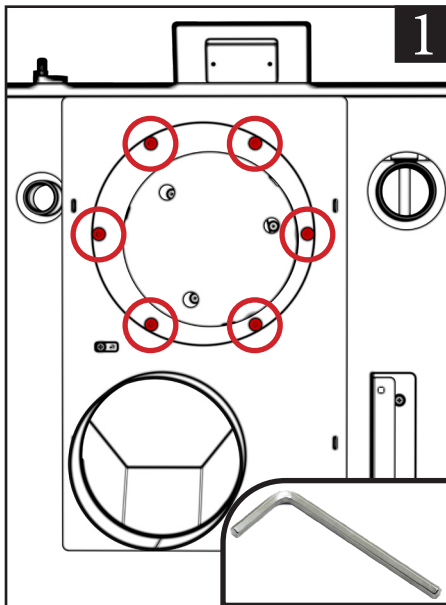

Remove the combustion fan from the connection points by unscrewing the 6 socket button head screw ISO 7380 - M6 x 8 holding it in place.

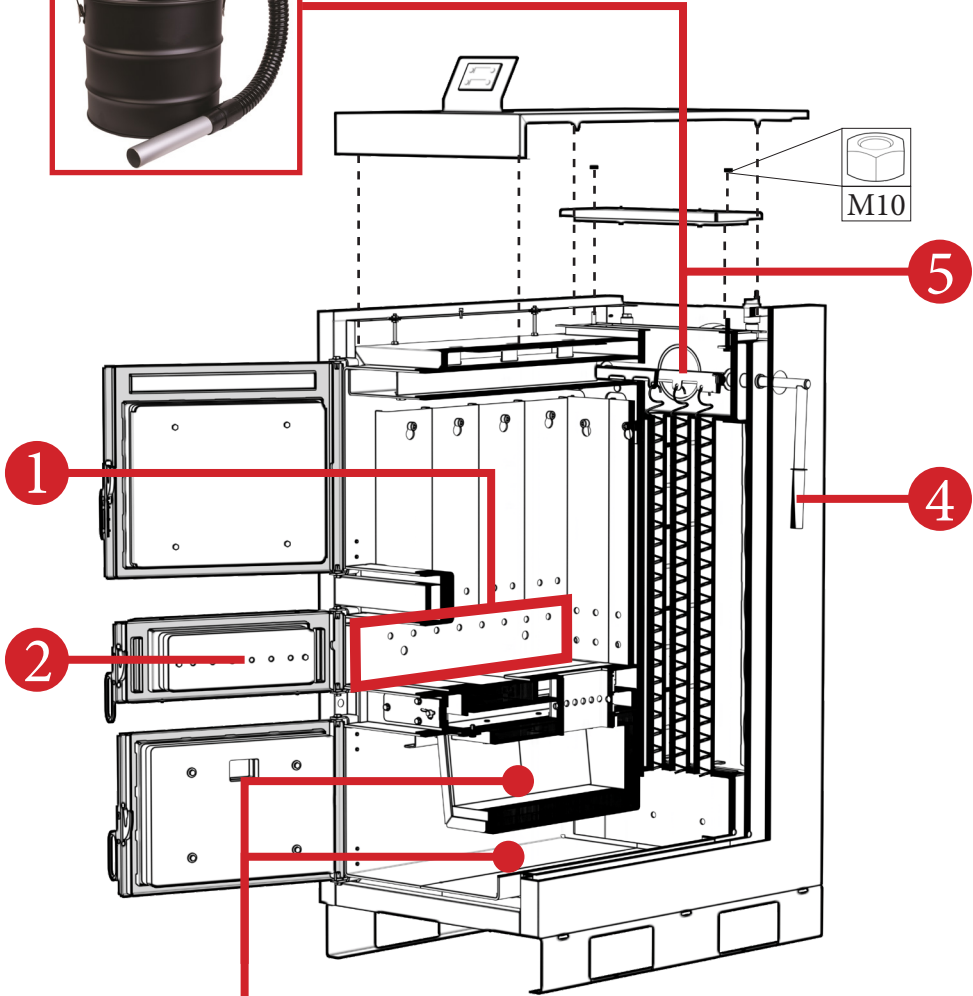

1

2

3

5

4

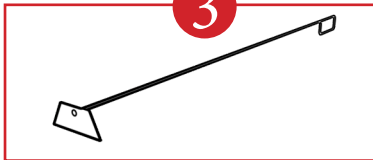

1

BEFORE EACH IGNITION

Before every ignition is necessary to clean the wood loading chamber from the ash. The canals for the primary air must always be clear of all residue. Use the special cleaning tool for this purpose.

2

BEFORE EACH IGNITION

Before every ignition is necessary to check if the holes for primary air located on the middle door are free of all residue.

3

BEFORE EACH IGNITION

Before every ignition is necessary to clean the main combustion chamber from the ash. Use the special cleaning tool for this purpose.

4

BEFORE REFILLING OF FUEL / BEFORE IGNITION

For flue gas tubes cleaning, it is necessary to pull lever left to right a few times.

5

AT LEAST ONCE PER YEAR

Cleaning of area over heat exchanger pipes with turbulators.

1 - Switch off the boiler and disconnect from power.

2 - Remove the top cover.

3 - Open the flue gas chamber by removing the 2 M10 nuts.

4 - Use the metal vacuum cleaner to clean dust and ash in flue gas chamber.

Control Panel: Use and Functions

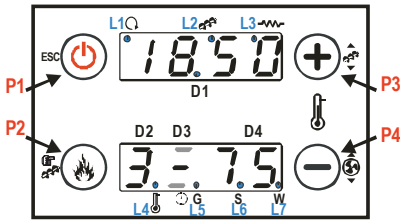

	KEY	CLICK	LONG PRESSED
P1	Visualisations / Exit Menu		Ignition / Extinguishing / Block reset
P2	Combustion Power modify / Save data		
P3	Thermostat modify (+) / Increase data		
P4	Thermostat modify (-) / Decrease data		Combustion Fan speed correction

Values shown on the main frame

Display D1: time, system state, error, Menu, Submenu, parameter value; Display D2: power, parameter code;

Display D3: recipe; Display D4: main temperature, parameter code.

ALARMS

Er01 - Security Error High Voltage 1. It may also intervene with the system off;
Er02 - Security Error High Voltage 2. It can only intervene if the Combustion fan is active;
Er05 - Extinguishing due to high exhaust temperature;
Er07 - Encoder Error. The error may occur due to lack signal from Encoder;
Er08 - Encoder Error. The error can occur due to problems of adjustment of the number of revolutions;
Er11 - Clock Error. The error occurs due to problems with the internal clock;
Er15 - Extinguishing due to power failure for more than 50 minutes;
Er44 - Open door error;
Service - Service error. It notifies that the planned hours of functioning (parameter T66) is reached. It is necessary to call for service.

FUNCTIONING STATE VISUALIZATION

State	Code	State	Code	State	Code
Off	-	Ignition-Variable ignition	On 4	Safety	SAF
Check Up	ChEc	Stabilization	On 5	Extinguishing	OFF
Ignition-Pre-heating	On 1	Run mode	-	Block	Alt
Ignition-Preload	On 2	Modulation	Mod	Ignition Recovery	rEc
Ignition-Fixed ignition	On 3	Standby	Stby		

MESSAGES

Description	Code
Anomaly of the probes checking, during Check Up phase.	Sond
Room temperature greater than 50 °C.	Hi
This message notifies that the planned hours of functioning (parameter T67) are reached.	CLr
Door Open.	Door
The message appears if the system is turned off during Ignition (after Preload) not manually: the system will stop only when it goes in Run Mode.	OFF dEL
Periodical Cleaning in progress.	PCLr
No communication between motherboard and keyboard	-

USER MENU 1

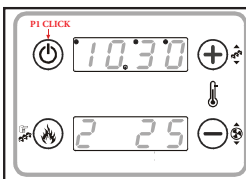

UF = Speed Combustion Fan [RPM];
tF = Exhaust flue gas temperature [°C];
tP = DHW Temperature / Buffer tank Temperature [°C];
tE = External temperature [°C];
St = Remaining time before the system notices the message 'Service'; [h];
St2 = Remaining time before the system cleaning is performed [h];

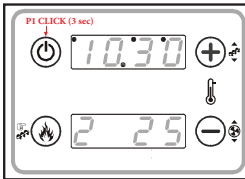

It is possible to activate the **ignition process** with long press on the **P1** button;
It is possible to activate the **extinction process** with long press on the **P1** button;
It is possible to clear the **Block** with long press on the **P1** button.

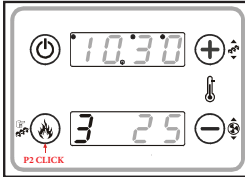

Combustion Power Setting

Click on **P2** button: the **D2** display blinks. With other click of the same button the power is changed. Ex.: 1-2-3-4-5-A (A=Automatic combustion). After 5 seconds the new value is saved and the display shows as normal.

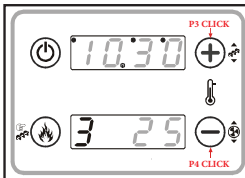

Thermostat Setting

Press the **P3** or **P4** key: the **D3** display blinks. With sequential clicks on the **P3 / P4** button, it is possible to increase or decrease the set temperature of the thermostat. After 5 seconds the new value is saved and the display shows as normal.

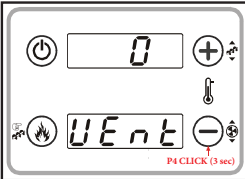

Combustion Fan Correction

The long pressure of **P4** button activates this function (You have to do it two times to access the modify modality). The bottom display shows **UEnt**, the upper display the value. With buttons **P3/P4** the value is increased or decreased; the default set is '0'. After 5 seconds the new value is saved and the display shows as normal.

USER MENU 2

The access to the menu is done by pressing **P2** and **P4** at the same time.

Fuel (FuEL)	This Menu allows to change the system operation switching from Wood (Uood) to Pellet (Pell)
--------------------	---

Thermostats (tErM)	boil / Boiler / This Menu allows to edit the Boiler Thermostat value. dHU / DHW / This Menu allows you to change the value of the DHW Thermostat. PuFF / Buffer Tank / This Menu allows you to change the value of the Buffer tank.
---------------------------	--

Clock (orOL) - This Menu allows to set time and date. The above display shows hour and minutes, the under display shows the day of the week. Push the button **P2** to enter editing. The selected value (hours, minutes, days) blinks. To change the value use the **P3/P4** button. Push the button **P2** to switch to modify the other parameters. Push again **P2** to save the set value.

Technical Menu (TPAr)	This menu allows to enter in the Technical Menu. "0000".
------------------------------	--

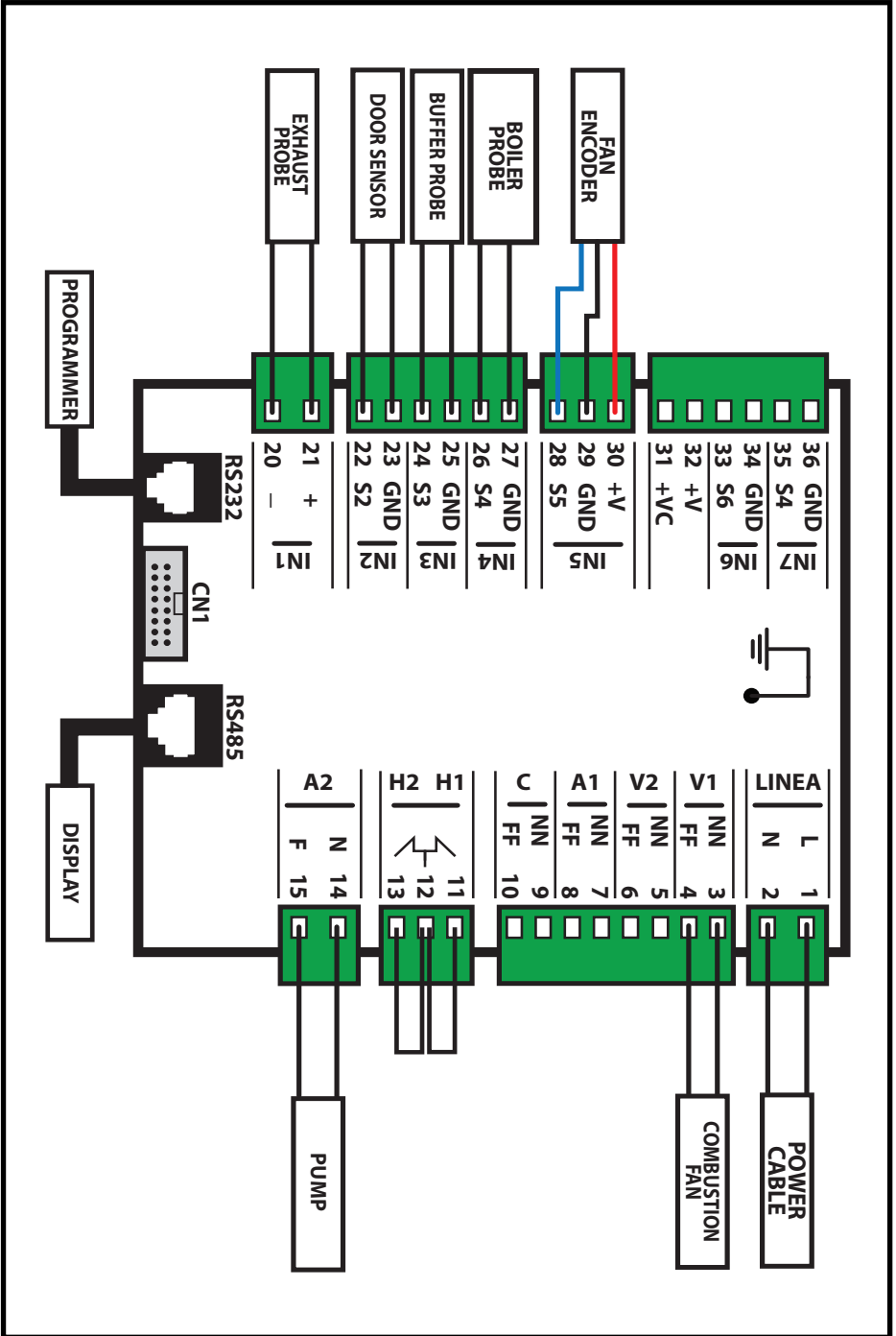



IMPORTANT !!!

1. The fuel to be used is only wood under 25% humidity content (wood dried min. 1 year).
2. The outlet temperature always has to be over 60°C. This can be reached by obligatory connection of the 3-way thermic valve which blocks the boiler temperature from falling under the 60°C level.
3. The connection of water tank is obligatory.
4. To the closed central heating system an expanding vessel has to be connected (the volume of the expanding vessel is about 10% of the installation volume).
5. To the open central heating system an open expanding vessel has to be connected, which volume has to be about 7% of the installation volume.



Mareli Systems

Mareli Systems

Industrial Zone
Simitli, 2730
Region Blagoevgrad
Bulgaria

info@mareli-systems.com
www.mareli-systems.com

MARELI SYSTEMS disclaims any responsibility for possible inaccuracies contained in this manual if they are due to printing or transcription errors. We reserve the right to make any change that appears to be necessary or useful without harm the essential characteristics.
